



**Multi range AC current clamps  
(1000A / 100A / 5A / 0.5A)**

**A 1281**

**Instruction manual**

*Version 2.1, Code no. 20 751 696*

***Distributor:***

***Manufacturer:***

METREL d.d.  
Ljubljanska cesta 77  
1354 Horjul  
Slovenia

web site: <http://www.metrel.si>

e-mail: [metrel@metrel.si](mailto:metrel@metrel.si)

© 2014 METREL



Mark on your equipment certifies that this equipment meets the requirements of the EU (European Union) concerning safety and electromagnetic compatibility regulations.

No part of this publication may be reproduced or utilized in any form or by any means without permission in writing from METREL.









---

## Table of contents

<b>DESCRIPTION OF CURRENT CLAMPS.....</b>	<b>5</b>
<b>CURRENT CLAMPS OPERATION.....</b>	<b>6</b>
OPERATION INSTRUCTIONS.....	6
SUBSTITUTE ELECTRIC MODEL FOR CURRENT CLAMPS .....	7
<b>TYPICAL APPLICATIONS.....</b>	<b>7</b>
POWER QUALITY MEASUREMENT .....	7
POWER MEASUREMENT .....	8
LEAKAGE CURRENT MEASUREMENT .....	8
<i>Measurement of Leakage Current by Direct Method.....</i>	<i>8</i>
<i>Measurement of Differential Current and/or Current Difference.....</i>	<i>8</i>
<i>Determining Problems in Lighting and Grounding Systems.....</i>	<i>9</i>
<b>MAINTENANCE .....</b>	<b>9</b>
INSPECTION .....	9
CLEANING .....	9
SERVICE AND CALIBRATION .....	9
<b>TECHNICAL SPECIFICATIONS.....</b>	<b>10</b>
GENERAL .....	10
ACCURACY AND PHASE ERROR .....	11
TYPICAL PERFORMANCE CHARACTERISTICS .....	11
ELECTROMAGNETIC COMPATIBILITY (EMC) .....	12

## Symbols and Warnings

To ensure a high level of operator's safety during using of A 1281 Multi range AC current clamps the following warnings has to be considered:

- ◆  **Do not use the current clamp if any damage is noticed!**
- ◆  **Consider all generally known precautions in order to avoid risk of electric shock while dealing with electric installations!**
- ◆  **Do not extend hands over safety barrier to prevent of electric shock! Only handles are allowed to be touched during measurement!**
- ◆  **Symbol on the current clamp indicates the possibility of a hazardous live condition if the operator ignores the required safety measures.**
- ◆  **If the current clamps are used in a manner not specified in this User manual, the provided protection can be impaired!**
- ◆  **Only a competent, authorized person is allowed to carry out service intervention!**
- ◆  **Do not connect clamp output elsewhere than to Metrel Power Quality Analyzer's!**
- ◆  **Symbol on the current clamp indicates the possibility to use the current clamp on non-insulated conductors.**
- ◆  **Current clamps are protected by double insulation.**

## Description of current clamps

The A 1281 multi range current clamps are designed for measuring alternating currents on low and medium power installations: 50 mA ÷ 1000 A.

They have electronic module, and can be connected only to Metrel Power Quality Analysers', series:

- PowerQ (MI 2492)
- PowerQ<sup>Plus</sup> (MI 2392)
- PowerQ4 (MI 2592)
- PowerQ4 Plus (MI 2792)
- Energy Master (MI 2883)
- Power Q4 (MI 2885)
- Power Master (MI 2892)
- Power Master XT (MI 2893)

Clamps have four current ranges 0.5A, 5A, 100A and 1000A, which are selected directly by the connected instrument. Embedded electronic module is powered directly from the connected instrument and does not need any additional power supply.

The current transducer is housed in a plastic case that maintains double insulation as defined in Main parts of the current clamps are shown on figure below:

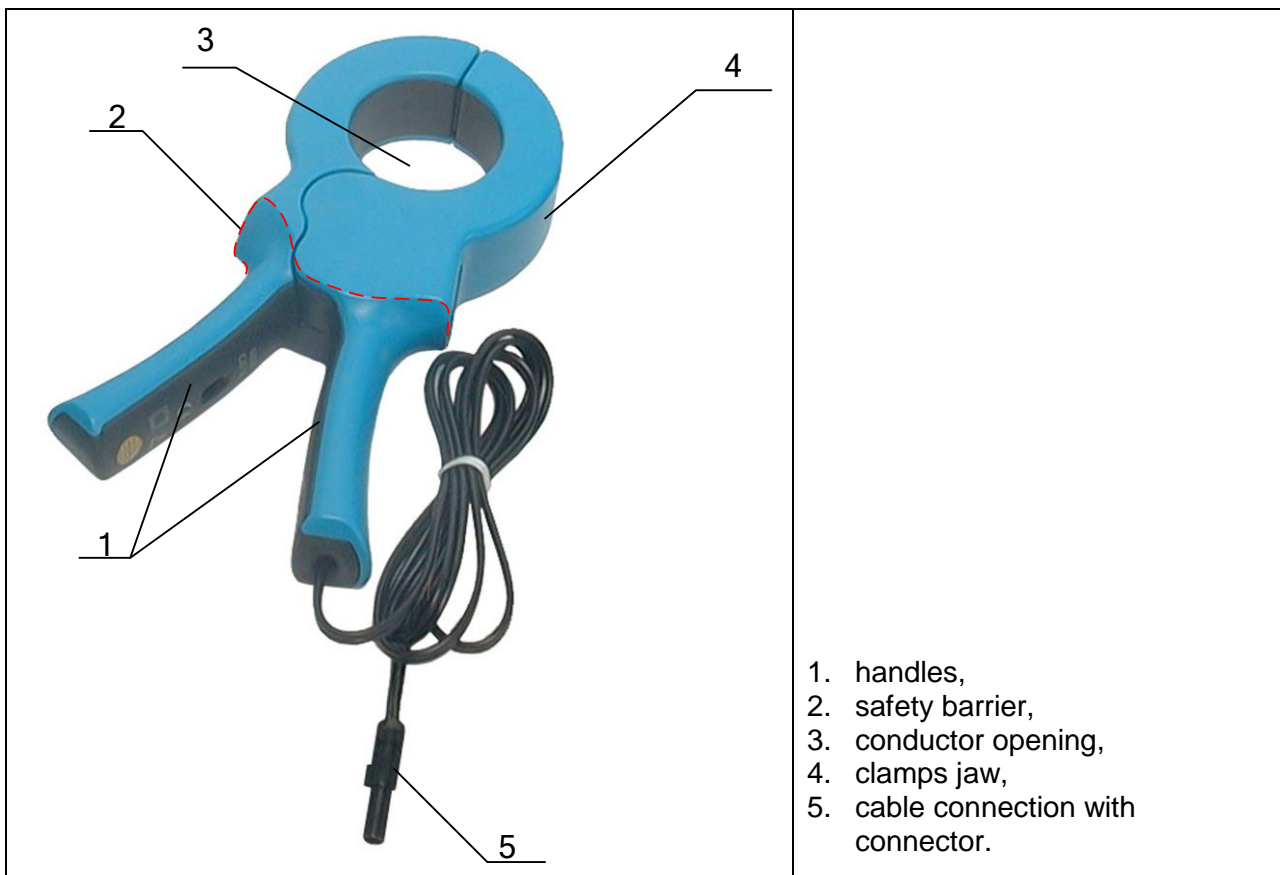

Figure 1: Multi range AC current clamps

## Current clamps operation

### Operation Instructions



Figure 2: Current clamps A 1281 - connection to the measuring instrument

#### Step 1

Connect A 1281 current clamps output connector to the appropriate (Metrel Power Quality Analyzer) measuring instrument's current input terminal. (See figure 2)

**⚠ Do not connect clamp output elsewhere than to Metrel Power Quality Analyzers' series of measuring instruments!**

#### Step 2

Switch on the measuring instrument. Set Smart clamps and range on instrument's measuring setup. (For further information see *Instruction manual of measuring instrument.*)

#### Step 3

Clamp the probe around the current-carrying conductor(s) to be measured. Make sure that probe jaws are tightly closed around the conductor(s).

**⚠ Do not extend hands over safety barrier to prevent of electric shock! Only handles are allowed to be touched during measurement!**

**⚠ Do not use the current clamp if any damage is noticed!**

**⚠ Consider all generally known precautions in order to avoid risk of electric shock while dealing with electric installations!**

#### Step 4

Make measurement. (For further information see *Instruction manual of measuring instrument.*)

**Step 5**

Disconnect clamps from the conductor(s). Use all safety measures as described in step 3.

**Substitute Electric Model for Current Clamps**

Equivalent circuit diagram for current clamp measurement:

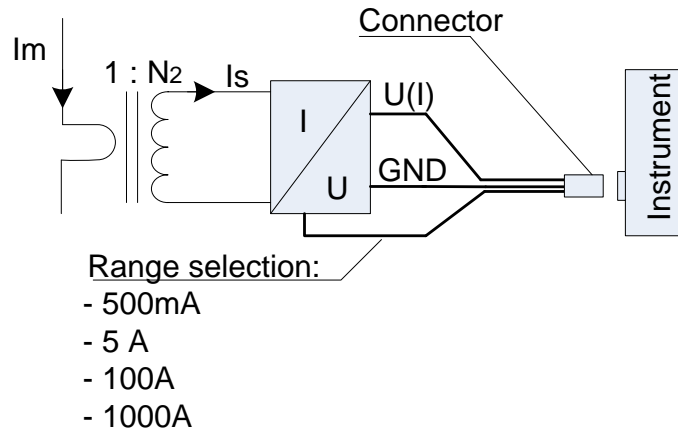

Figure 3: Current clamps A 1281 - block diagram

Symbols on circuit diagrams have following meaning:

- $I_m$  Measured (AC) current, primary current  
 $I_s$  Measured current, current transformer secondary current  
 $N_2$  Number of secondary turns ( $N_2 = 1000$ )  
 $U(I)$  Output voltage as function of current  $U = k * I_m$ . Factor k depends on selected current range as shown in table below:

Range (A)	k (V/A)
0,5	2
5	0,2
100	0,01
1000	0,001

**Typical applications****Power Quality Measurement**

A 1281 current clamps have linear response through wide frequency bandwidth (see Figure 8). Therefore, they are well suited for:

- Power Quality auditing,
- EN 50160 or troubleshooting. Particularly for:
- Current distortion measurement
- Inrush measurement
- Functional testing of appliances, machines, etc.

High precision (see Figure 6) and wide measurement range can cover most of practical LV current measurements.

## Power Measurement

A 1281 current clamps have small phase shift (see Figure 7 and Figure 9) over wide frequency range. Therefore, they are well suited for:

- Power and energy measurements (active, reactive, apparent)
- Power factor measurements
- Power/Energy efficiency

## Leakage Current Measurement

### Measurement of Leakage Current by Direct Method

This method is used when measuring the current through one (embraced) conductor.

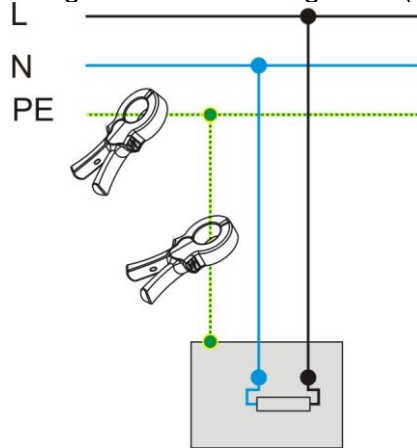

Figure 4: Leakage current measurement – direct method

### Measurement of Differential Current and/or Current Difference

The differential method sums the current passing through two or more active (embraced) conductors. If no current is leaking to earth, the sum of the currents passing through active conductors must be exactly zero regardless of the load currents. If a leakage current is flowing to earth, it must be equal to the difference in current between the conductors contained in the current clamp (although, if alternative earth paths exist, this may not be equal to the current passing through the PE conductor).

#### Note

Note that the direction of currents in the conductors must be considered if the differential method is used.

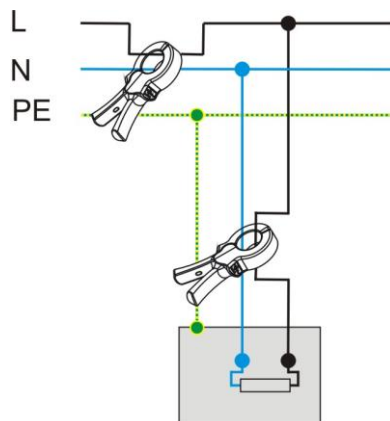

Figure 5: Leakage current measurement – differential method



## Determining Problems in Lighting and Grounding Systems.

Faults in electrical installations and equipment can cause additional continuous or short-lasting leakage currents. Typical faults that can cause increased leakage currents are:

- Deterioration of insulation (because of pollution, moisture, corrosion). This is causing a gradual increase of the resistive leakage current.
- Faults in electronic equipment.
- If the neutral and PE wiring are connected together anywhere in the installation this can result in an improper current distribution through the neutral and PE conductors.

### Note

Metrel Application note: *Measuring of leakage current* contain many practical aspects and examples of leakage current measurement.

## Maintenance

### Inspection

To maintain operator safety and ensure reliability of the current clamp it is good practice to inspect it on a regular basis. Check that the enclosure and optional connection are without defects such as scratches or breaks.

Jaw surface must be clean. Pollution on jaw surfaces reduces the current clamp sensitivity.

### Cleaning

Use a soft cloth moistened with soapy water or alcohol to clean non-metallic surface of the current clamps and leave them to dry totally before using it.



**Do not use liquids based on petrol or hydrocarbons!**



**Do not spill cleaning liquid over the current clamps!**

To clean jaw cut surfaces use slightly oiled soft cloth.

### Service and Calibration

It is essential that your clamp is regularly calibrated in order to guarantee the technical specification listed in this User manual. We recommend 2-year calibration interval. Metrel encloses an original calibration certificate with every new instrument and clamp.

For recalibration and repairs under or out of warranty time please contact your distributor for further information.



**Only a competent, authorized person is allowed to carry out service intervention!**

## Technical Specifications

### General

#### Safety specification

Over voltage category: 600 V CAT III,  
Pollution degree: 2  
Double insulation

#### Environment conditions

Working temperature:  $-20\text{ }^{\circ}\text{C} \div 55\text{ }^{\circ}\text{C}$   
Storage temperature:  $-30\text{ }^{\circ}\text{C} \div 70\text{ }^{\circ}\text{C}$   
Temperature dependency (Note 1):  
 $\pm 0.02\%$  of reading /  $^{\circ}\text{C}$   
Humidity:  $0\% \div 85\%$ ,  
Linearly decreasing for  $T > 35\text{ }^{\circ}\text{C}$   
Altitude:  $\leq 2000\text{ m}$

#### Applied standards

Safety: EN/IEC 61010-1  
EN/IEC 61010-2-32  
EMC: EN/IEC 61326-1

#### Mechanical data

Jaw opening: 52 mm

#### Maximum conductor sizes:

Cable:  $< 50\text{ mm}$   
Bar: 1 bar  $50\text{ mm} \times 5\text{ mm}$ ,  
4 bars  $30\text{ mm} \times 5\text{ mm}$

Housing flammability: UL94 – V-1

Dimension:  $220\text{ mm} \times 120\text{ mm} \times 48\text{ mm}$

Weight: 600 g

---

Note 1: No additional error in range  $15\text{ }^{\circ}\text{C} - 25\text{ }^{\circ}\text{C}$ ,

- for higher temperatures: Temp. error =  $(\text{Temp} - 25\text{ }^{\circ}\text{C}) * \text{Temperature dependency}$
- for lower temperatures: Temp. error =  $(15\text{ }^{\circ}\text{C} - \text{Temp}) * \text{Temperature dependency}$

**Accuracy and Phase Error**

Reference conditions: Temperature: 23 °C ± 1 °C Humidity: 60 %		Current range			
Nominal current (I <sub>Nom</sub> )		0.5 A	5 A	100 A	1000 A
Current ratio		0.5 A/V	5 A/V	100 A/V	1000 A/V
Peak current		1.5 A <sub>PEAK</sub>	15 A <sub>PEAK</sub>	246 A <sub>PEAK</sub>	1700 A <sub>PEAK</sub>
Crest factor @ Nominal current		3,0	3,0	2,46	1,7
Accuracy	Current range*	50 mA ÷ 1 A	0.5 A ÷ 10 A	10 A ÷ 175 A	100 A ÷ 1200 A
	RMS Current Accuracy	0.5 % of m.v.	0.5 % of m.v.	0.5 % of m.v.	0.5 % of m.v.
	Frequency range	40 Hz ÷ 700 Hz (<0.5° phase error) 700 Hz ÷ 2500 Hz (<3° phase error)			
Continuity of measurements		1000 A continuous 1200 A (40 min / 20 min intermitted)			
Load impedance		< 1 kΩ			
Working voltage		600 Vrms			
Influence of neighbour conductor:		< 1 mA/A at 50 Hz			
Influence of conductor position:		< 0.3 % at f < 400 Hz			

\*Accuracy for 0÷10% range is 0.1% · I<sub>Nom</sub>  
m.v. – measured value

**Typical Performance Characteristics**

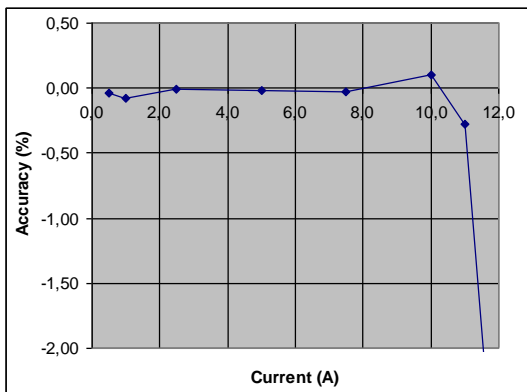

Figure 6: Accuracy vs. current (for 5A range)

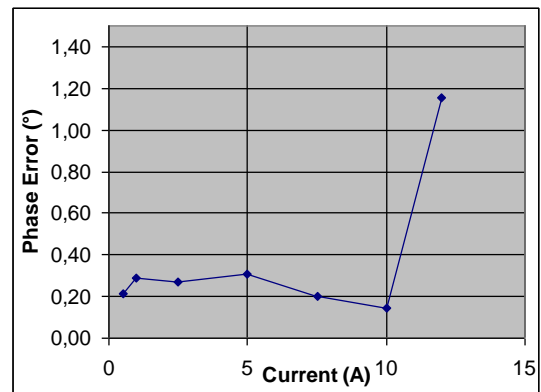

Figure 7: Phase error vs. current (for 5A range)

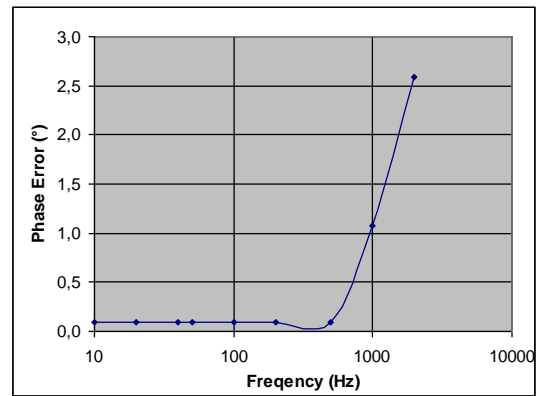
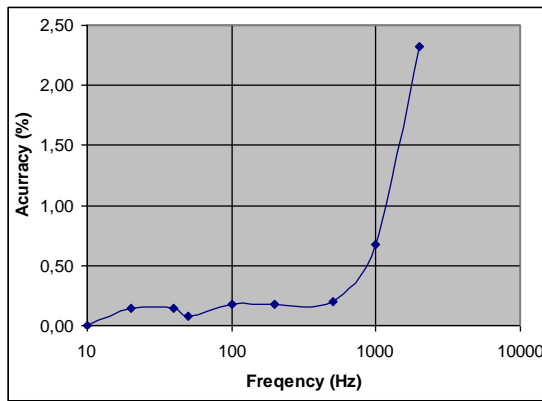

Figure 8: Accuracy vs. frequency (for 5A range) Figure 9: Phase error vs. frequency (for 5A range)

### Electromagnetic Compatibility (EMC)

Current clamps A 1281 conforms to the directive 2004/108/EC for EMC, as defined by EN-61326-1:

- Emission: Class B (domestic and industrial use).
- Immunity: Intended for use in industrial locations, but can also be used for domestic purposes (Performance criteria B), with addition to the tables below:

Table 1: Immunity to radiated RF fields\*

Range	Operational conditions	Disturbance < 0,2 %	Disturbance > 0,2 %
0.5A	0.05 A ÷ 0.5 A	322 MHz ÷ 1 GHz	80MHz ÷ 322 MHz
5A	0.5 A ÷ 5 A	250 MHz ÷ 1 GHz	80MHz ÷ 250 MHz
100A	10 A ÷ 100 A	80 MHz ÷ 1 GHz	–
1000A	100 A ÷ 1000 A	80 MHz ÷ 1 GHz	–

\* Field strength: 10V/m, Modulation: AM, 80%, 1 kHz

Table 2: Immunity to Magnetic field\*

Range	Operational conditions	Disturbance
0.5A	0.05 A ÷ 0.5 A	< 6 % of m.v.
5A	0.5 A ÷ 5A	< 0.5 % of m.v.
100A	10 A ÷ 100 A	< 0.2 % of m.v.
1000A	100 A ÷ 1000 A	< 0.2 % of m.v.

\*Field strength: 30 A/m, Modulation: AM, 80%, 1kHz.

Label1