

ANAFI™

— T H E R M A L —

The ultra-compact, fully-integrated thermal drone

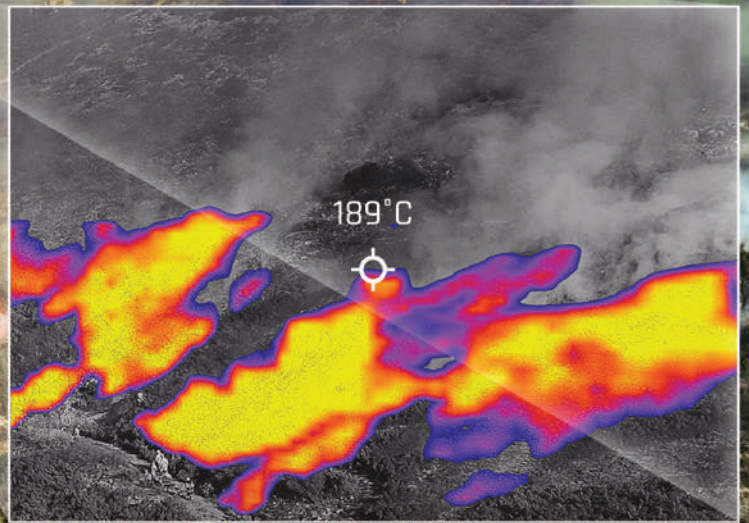

Thermal & visible
imagery

Compact,
yet powerful

Easy-to-use
Solution

Parrot®



THERMAL & VISIBLE IMAGERY

TWO INTEGRATED SENSORS WORKING IN FULL SYNCHRONIZATION

- FLIR radiometric thermal sensor¹: 160x120 resolution, 57° HFOV, -10°C to +400°C temperature range
 - Sony Sensor² for visible images (RGB): 1/2.4" 21MP CMOS, 4K HDR video recording capabilities
- Blended thermal & RGB images in thermal view (temporal synchronisation of thermal & RGB images)
 - Record videos and capture pictures in thermal or visible formats (video quality: 1440x1080p in thermal view / 4K HDR in visible view)
- 3-axis hybrid stabilisation (2-axis mechanical combined with 3-axis digital stabilisation)
 - +/-90° = 180° camera tilt (Zenith to Nadir views)
 - Zoom function (3x digital zoom in thermal view)



COMPACT & POWERFUL

OPTIMIZED PERFORMANCES IN AN ULTRA-PORTABLE SOLUTION

- All-in-one: everything you need in one solution
- Easy-to-carry solution in its compact shoulder bag which fits smartphones or tablets
 - Fast and easy to unfold drone for ultra quick set-up (less than 3 seconds)
 - Ultra-compact, lightweight yet robust carbon-reinforced drone design
- Up to 26 minutes flight time per Smart Battery (3 smart batteries included)
 - USB-C on-the-go charging system (compatible with Powerbanks)
 - Multi-port USB charger to charge all 3 batteries together in 3h30
 - Perfect stability against winds of up to 50 km/h
 - Super quiet flights



EASY-TO-USE

USER-FRIENDLY INTERFACE TO CAPTURE AND ANALYZE THERMAL AND RGB DATA

- Intuitive manual flight with FreeFlight 6 mobile app
- Easy dual-use of thermal & visible views in one app, on one screen
- Automatic scouting with FlightPlan³: autonomous flight made easier (to capture either thermal or RGB images)
- Compatible with Pix4Dcapture for optimal automatic RGB data acquisition
 - Smart RTH and Geofence for safer flights
- Direct in-app analysis of thermal images (videos & pictures) using FreeFlight 6:
 - In-app customized color palettes
 - Temperature of each point
 - Min and max temperature of each scene

1. FLIR is a registered trademark of FLIR® Systems, Inc

2. Sony is a registered trademark of Sony Corporation

3. FlightPlan is available at no additional cost within the FreeFlight 6.5 version when using an ANAFI Thermal



TECHNICAL SPECIFICATIONS

Drone

- Size folded: 218x69x64mm
- Size unfolded (propellers unfolded): 242x315x64mm
- Weight: 315g
- Max transmission range: 4km with Parrot SkyController 3
- Max flight time: 26min
- Max speed: 55km/h
- Max vertical speed: 4m/s
- Max wind resistance: 50km/h
- Service ceiling: 4.500m above sea level
- Operating temperature: -10°C to 40°C

Sensors:

- GNSS: GPS + GLONASS
- Barometer and magnetometer
- Vertical camera and ultra-sound sensor
- 2x6-axis IMU
- 2x3-axis accelerometers
- 2x3-axis gyroscopes

Controller

- Size folded: 94x152x72mm
- Size unfolded: 153x152x116mm
- Weight: 386g
- Transmission system: Wi-Fi 802.11a/b/g/n
- Operating frequencies: 2.4GHz – 5.8GHz
- Max transmission range: 4km
- Live streaming resolution: 720p (HD) 1280x720
- Battery capacity: 2,500mAh 3.6V
- Supported mobile devices:
 - Without tablet holder: screen size up to 6.2"
 - With tablet holder: screen size up to 10"
- USB ports: USB-C (charge), USB-A (connection)

RGB camera

- Sensor: CMOS 1/2.4", 21MP
- LD-ASPH lens:
 - Aperture: f/2.4
 - Focal length: 26mm (equivalent 35mm)
- Depth of field: 1.5m to infinity
- Video format: MP4 (H264)
- Video resolution:
 - 4K Cinema (4096x2160 24fps)
 - 4K UHD (3840x2160 24/25/30fps)
 - FHD (1920x1080 24/25/30/48/50/60fps)
 - HD (1280x720 96/100/120fps)
- Video HFOV: 69°
- HDR: 4K UHD, 2.7K and 1080p videos, JPEG photos
- Digital zoom:
 - Lossless: up to x2.8 (FHD), up to x1.9 (2.7K), up to x1.4 (4K UHD)
 - Standard: up to 3x (all resolutions)
- Photo formats: JPEG, DNG (RAW)
- Photo modes: single, burst, bracketing, timer and panorama
- Photo resolution:
 - Wide: 21MP (5344x4016) / 4:3 / 84° HFOV
 - Rectilinear: 12MP (4000x3000) / 4:3 / 75.5° HFOV
- Shutter speed: 1 to 1/10000s
- ISO: 100 to 3200
- EV compensation: [-3, +3]
- Max video bitrate: 100Mbps

Image stabilization

- 3-axis hybrid stabilization:
 - Mechanical: 2-axis (roll & pitch)
 - Electronic (EIS): 3-axis (roll, pitch & yaw)
 - Controllable tilt range: -90° to +90° (nadir to zenith)

Thermal camera

- Sensor: microbolometer FLIR LEPTON 3.5 (radiometric)
- Resolution: 160x120
- HFOV: 57°
- Pixel pitch: 12µm
- Spectral band: 8-14µm
- Photo format: JPEG
- Photo resolution: 3264x2448 (4/3)
- Photo modes: Single / Timelapse / GPS Lapse
- Video format: MP4 (H264)
- Video recording resolution: 1440x1080, 9fps
- Precision: ±5% max.(High-gain) or ±10% max.(Low-gain)
- Scene Dynamic Range: -10° à +140°C (High-gain) or -10° à +400°C (Low-gain)
- Video: MP4

Smart battery

- Type: LiPo 2S
- Capacity: 2700mAh
- Voltage: 7.6V
- Weight: 124g
- Temperature range: -20°C / 60°C
- Charging time: 1h15
- Max charging power: 26.1W (3A * 8.7V)

Charger

- Power: 52 W
- Input AC: 100–240 V, 50–60 Hz, 1,5A (Max)
- Output:
 - 4x USB: DC 5V/6.8A (each 2.4A Max)
 - USB quick charge 3.0: DC 3.6V-6.5V/3A, 6.5V-9V/2A, 9V-12V/1.5A
- Energy efficiency: Level VI
- Dimensions: 95x28.8x61mm
- Weight: 200g
- AC Power Cords: US, EU, UK

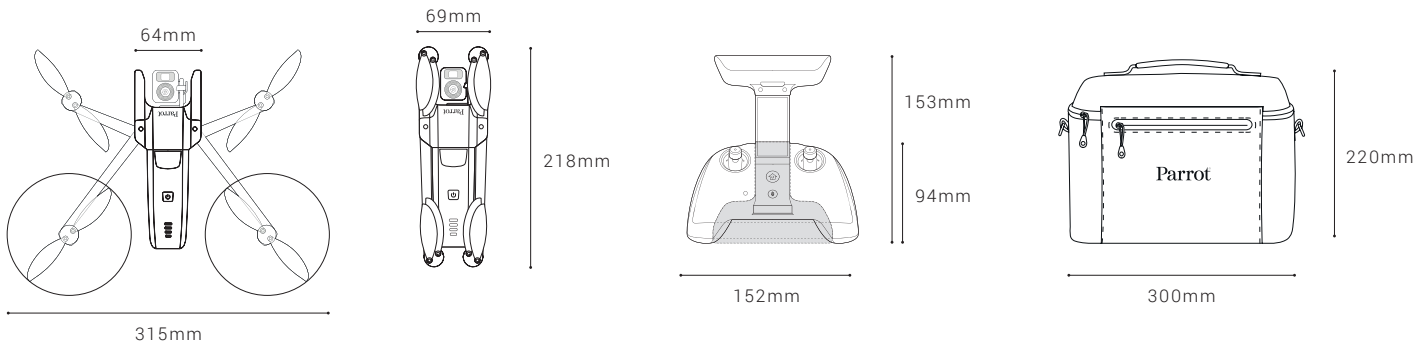

PACK CONTENT

- 1 ANAFI Thermal drone, 1 Parrot SkyController 3, 1 shoulder bag, 3 smart batteries, 1 multi-port USB charger, 1 tablet holder, 8 additional propeller blades & mounting tool, 16GB microSD card, 4 USB-A/USB-C cables

Parrot[®]

ANAFI Thermal WHITE PAPER

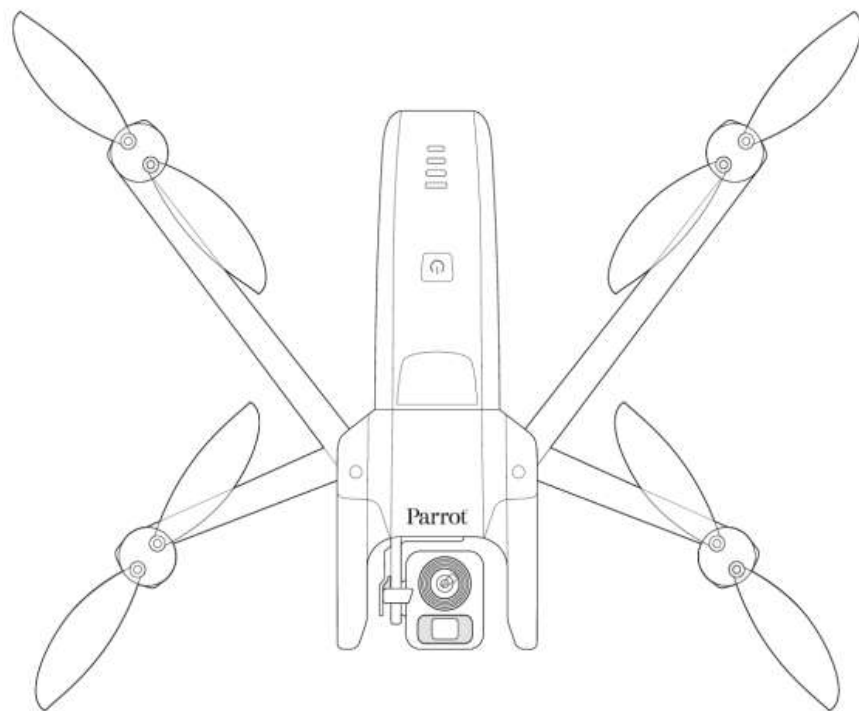

TABLE OF CONTENTS

1	AIRFRAME/AERODYNAMICS.....	4
1.1	AIRFRAME.....	4
1.1.1	<i>Keys characteristics.....</i>	4
1.1.2	<i>Durability.....</i>	4
1.2	AERODYNAMICS.....	4
1.2.1	<i>Key characteristics.....</i>	4
1.2.2	<i>Performance.....</i>	5
1.2.3	<i>Quality.....</i>	5
2	GIMBAL/IMAGING.....	6
2.1	GIMBAL.....	6
2.1.1	<i>Key characteristics.....</i>	6
2.1.2	<i>Performance.....</i>	6
2.1.3	<i>Video hybrid stabilization.....</i>	6
2.1.4	<i>180° tilt.....</i>	6
2.1.5	<i>Vision without artefacts.....</i>	6
2.1.6	<i>Durability.....</i>	6
2.1.7	<i>Quality.....</i>	7
2.2	VISIBLE IMAGING.....	7
2.2.1	<i>Key characteristics.....</i>	7
2.2.2	<i>HDR.....</i>	7
2.2.3	<i>Optical unit.....</i>	7
2.2.4	<i>Optical performance.....</i>	8
2.2.5	<i>Optical unit manufacturing; Active alignment.....</i>	8
2.2.6	<i>Quality.....</i>	9
2.3	INFRARED IMAGING.....	9
2.3.1	<i>Key characteristics.....</i>	9
2.3.2	<i>Double camera module.....</i>	9
2.3.3	<i>Color modes.....</i>	10
2.3.4	<i>Infrared / Visible fusion.....</i>	12
2.3.5	<i>About infrared streaming.....</i>	12
3	FLIGHT CONTROLLER/FLIGHT MODES	13
3.1	KEY CHARACTERISTICS.....	13
3.2	FLIGHT CONTROLLER.....	13
3.2.1	<i>Components.....</i>	13
3.2.2	<i>Sensor performance.....</i>	13
3.2.3	<i>Estimation algorithm.....</i>	14
3.2.4	<i>Control loop.....</i>	15
3.3	FLIGHT MODES.....	15
3.3.1	<i>Precise Hovering.....</i>	15
3.3.2	<i>Precise Return Home (RTH).....</i>	15
3.3.3	<i>Smart RTH.....</i>	16
3.3.4	<i>Automated take-off.....</i>	16
3.3.5	<i>Hand take-off.....</i>	16
3.3.6	<i>Low altitude flight.....</i>	16
3.3.7	<i>Automated landing.....</i>	16
3.4	FLYING MODES.....	16
3.4.1	<i>Manual.....</i>	16
3.4.2	<i>Automatic.....</i>	17

4	FREEFLIGHT 6.....	20
4.1	KEY CHARACTERISTICS	20
4.2	HUD	20
4.3	FLIGHT PLAN UI	21
4.4	MAP BACKGROUNDS	21
4.5	VISUALIZING MEDIA	22
4.6	AUTOMATED UPDATES	22
4.7	GSDK	22
5	VIDEO STREAMING	24
5.1	KEY CHARACTERISTICS	24
5.2	STREAM PERFORMANCE.....	24
6	BATTERY	25
6.1	KEY CHARACTERISTICS	25
6.2	PERFORMANCE	25
6.3	FEATURES	25
6.3.1	<i>Smart power management.....</i>	25
6.3.2	<i>Wintering.....</i>	25
6.3.3	<i>Storage.....</i>	26
6.3.4	<i>Smart charging.....</i>	26
6.3.5	<i>USB-C Interface.....</i>	26
6.3.6	<i>Powerbank.....</i>	26
6.3.7	<i>Charge indicator.....</i>	26
6.4	QUALITY	26

This document describes the specifications of the ANAFI Thermal drone.

1 AIRFRAME/AERODYNAMICS

1.1 Airframe

1.1.1 Keys characteristics

- ANAFI Thermal is the most compact 4K thermographic drone on the market
- Ultralight: 315 g
- Extremely easy to carry while folded (218x69x64mm)
- ANAFI Thermal unfolds in 1 second

Airframe characteristics

<i>Unfolded (LxWxH)</i>	<i>242x315x64mm</i>
<i>Folded (LxWxH)</i>	<i>218x69x64mm</i>
<i>Weight</i>	<i>315 g</i>
<i>Ready to fly</i>	<i>28 seconds</i>
<i>Temperature Range</i>	<i>-14 °C/40 °C</i>
<i>Humidity</i>	<i>93 % HR</i>

1.1.2 Durability

The mechanical structure of ANAFI Thermal is made of carbon fiber reinforced polyamide, lightened by hollow glass beads. ANAFI Thermal has passed the following durability tests:

- Exposure to moist heat (+40 °C and 93 % humidity rate) for 16 h
- Exposure to dry heat (T =+50 °C) for 16 h
- Exposure to thermal shocks: 20 cycles of 1 h at -10 °C and +50 °C
- Exposure to extreme temperatures: -20 °C/+70 °C for 4 h
- Exposure to low temperatures: -10 °C for 16 h
- ANAFI Thermal flies in the rain
- 400 flight hours without any mechanical wear at ambient temperature

As of today, the ANAFI Thermal fleet has accumulated more than 20,000 flight hours.

1.2 Aerodynamics

1.2.1 Key characteristics

- ANAFI Thermal's propeller design has allowed us to earn a 68 % figure of merit vs. 54 % for our competitors.
- ANAFI Thermal's powerful motors (60 W) have a 71 % yield (Pmech/Pelec) while stationary. They have been designed to get the best out of the propellers over the full flight range.
- Weight/autonomy ratio: the 25-minute flight time, light weight structure (320 g) and the high yield of its conversion chain allows ANAFI Thermal to fly fast (54 km/h) and far (14 km)
- Wind resistance: 50 km/h
- Wind gust resistance: 80 km/h
- Inconspicuous: ANAFI Thermal is a lot quieter (65.5 dB at 1 m) than any other comparable drone.

1.2.2 Performance

Aerodynamic performance	
Speed	15 m/s
Max Wind Speed Resistance	50 km/h
Flight time	26 min
Max Ascent Speed	4 m/s
Max Descent Speed	4 m/s
Speed at 2500 m	13 m/s
Max service ceiling	4800 m
Max distance	14 km at 11.5 m/s
Max Angular Velocity	200°/s

1.2.3 Quality

- Parrot is ISO9001 certified.
- Every drone is controlled on a production bench (FVT).
- Bench #2: IMU thermal calibration plus barometer and magnetometer test.
- Bench #3: IMU & magnetometer dynamic calibration.
- Bench #4: motor disturbance measure on the magnetometer.
- Bench #5: ultrasound test.
- Flight test: every drone performs a flight test at the end of the production process: takeoff, hovering, landing.
- Numerous durability tests are performed in the course of our development cycles. These take the form of a quest for the optimal drone size.

ANAFI Thermal Quality Control data and tests results are available upon request.

2 GIMBAL/IMAGING

2.1 Gimbal

ANAFI Thermal's gimbal enjoys the most precise stabilization system on the light drone market.

2.1.1 Key characteristics

- Hybrid stabilization: both mechanical and electronic
- Precision: $\pm 0.004^\circ$
- Usable tilt capabilities: 180° [nadir (-90°) to zenith ($+90^\circ$)]

2.1.2 Performance

Gimbal performances	
Angular accuracy of Image stabilization:	$\pm 0.004^\circ$
Mechanical Range	-140° $+110^\circ$ tilt
Controllable Range:	-90° $+90^\circ$ tilt
Max Control Speed:	$180^\circ/s$
Protection:	Against overload Against overheating Against excessive voltage

2.1.3 Video hybrid stabilization

ANAFI Thermal's video is stabilized over 5 axes (2 mechanical axes et 3 electronic axes) allowing it to reach a precision level of 0.004° - paramount for the zoom feature. The integrated inertial unit located closest to the camera tracks its movement at 8 kHz.

GIMBAL
2 mechanical axes: roll and pitch
3 electronic axes EIS (Electronic Image Stabilization): roll, pitch and yaw

The EIS algorithm corrects the wide-angle lens distortion, the wobble effect to which the drone's vibrations give rise, and numerically stabilizes images along 3 axes (roll, pitch, yaw).

2.1.4 180° tilt

The mechanical structure of the gimbal allows an extreme vertical tilt of 180° enabling inspection and observation from directly beneath an identified surface or zone. ANAFI Thermal is the only light drone on the market with this feature.

2.1.5 Vision without artefacts

To maximize the quality of each shot, the propellers and hull are designed to never interfere with the field of view of the camera.

2.1.6 Durability

The gimbal and the camera module are mechanically protected by the fork. The gimbal is also protected against overloads (it unlocks when it is applied a torque for more than 10 seconds), surges and excessive temperature (120°C).

2.1.7 Quality

- The gimbal has been tested on a dedicated test bench for more than 100 hours straight, without any defect or visible wear.
- All gimbals are production tested on bench #4.
- The motors of the gimbal are controlled.
- Hall effect sensor control: amplitude, bias and noise.

ANAFI Thermal gimbal Quality Control data and tests results are available upon request.

2.2 Visible imaging

2.2.1 Key characteristics

- Camera module equipped with a SONY IMX230 1/2.4" sensor
- Video: 4K HDR (30 fps)
- Photo: 21 Mp
- Angular resolution: 0.048°
- MTF resolution: > 50 at 160 lp/mm
- Lossless zoom: x2.8 at 1080 p

Video resolution
4K Cinema 4096x2160 24 fps
4K UHD 3840x2160 24/25/30 fps
FHD 1920x1080 24/25/30/48/50/60 fps
HFOV Video: 69°
Video stream max speed: 100 Mbps
Video format: MP4 (H264)
Photo resolution
HDR: 4K UHD video
Wide: 21MP (5344x4016) / 4:3 / 84° HFOV
Rectilinear: 16MP (4608x3456) / 4:3 / HFOV 75.5°
Photo formats: JPEG, Adobe DNG (RAW)

2.2.2 HDR

The HDR algorithm restores up to 14 EV. The sensor exposes half of the pixels over a long period while the other half are exposed for a shorter period, avoiding artefacts due to movement. Both exposures are then fused to produce an image of the same definition as that native to the sensor (21MP) while optimizing contrast and reducing resolution loss in the finer details of the image.

The ISP defines exposure times depending on the scene as well as final image optimization (contrast, color, noise reduction).

2.2.3 Optical unit

We are using a low dispersion aspheric lens architecture (Diagonal FOV of 110°). The sensor is made of six lenses optimized to minimize the level of parasitic light while providing a high-resolution image across a vast temperature range (-10 °C to +50 °C). Very low dispersion glass and six aspheric lenses have been combined to warrant a minimal aberration level on the entire temperature range.

2.2.4 Optical performance

ANAFI Thermal'S Optical performance	
Angular resolution	0.048°
MTF resolution	> 50 to 160 lp/mm
Lossless zoom	x2.8 at 1080p
Real focus	4.04mm +/- 5 %
Aperture	f/2.39 +/- 5 %
Exposure time	1 second - 1/10000 s
ISO range	100 to 3200

2.2.5 Optical unit manufacturing: Active alignment

The optical unit is assembled with the Sony sensor using an Active alignment technique. The optical block is positioned and held in place using a robotic arm, to achieve the following performance:

- the optical block is positioned above the sensor to ensure the desired focus at a set temperature (23 °C +/- 2 °C) and to guarantee resolution specifications in the scene;
- in yaw, roll and pitch, the optical block is position respecting the optical axis to obtain a uniform resolution on the edge of images;
- the sensor is aligned with the optical block axis to get the best performance at the center of the image;
- the optical center is finally aligned with the sensor center (+/- 20 pixels or 22 micrometer).

To guarantee the ISP's image quality specifications, the factory performs an image calibration. In its internal memory, each optical unit carries the optical center, a dead pixel mapping, a lens shading mapping (luminance and color) and white balance.

Fig. 3 - Active alignment camera assembly

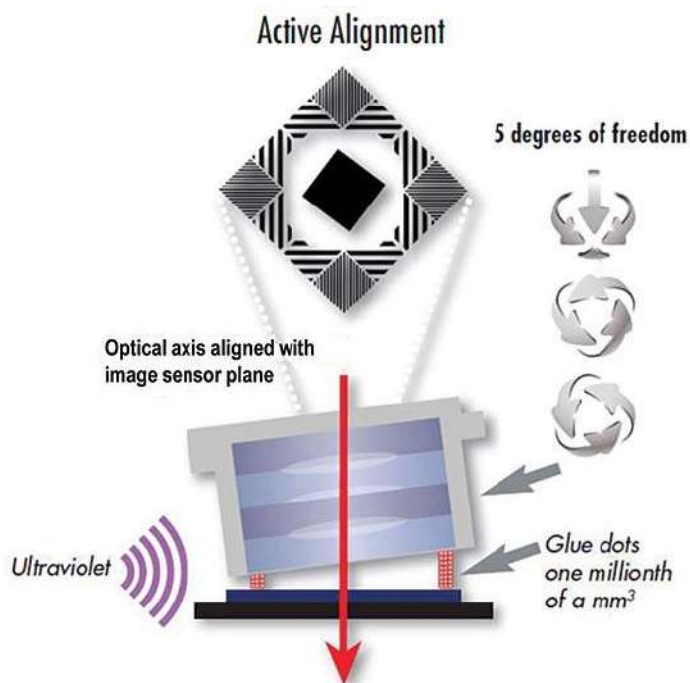

2.2.6 Quality

Several optical tests are performed in the course of the production process:

- MTF checks on the image center
- MTF checks on the image borders
- Camera module checks while in production:
 - Center MTF
 - MTF at 40 % of the field
 - MTF at 70 % of the field
 - Light blemishes (dark or light areas on the image, dust suspicions)
 - Dead pixels (checking the total number)
 - Optical center
 - Uniformity of brightness and color in the field
 - Cosmetic defects (stains, scratches, etc.)

2.3 Infrared imaging

ANAFI Thermal is the ANAFI variant equipped with an integrated double sensor, infrared and visible 4K.

2.3.1 Key characteristics

- IR/EO system on ANAFI Thermal gimbal
- Blending visible and infrared spectrum
- Thermal radiometric camera model: Lepton® 3.5 by FLIR
- Automatic sensor recalibration

2.3.2 Double camera module

The double camera module is stabilized by ANAFI Thermal's gimbal.

Fig. 12 - Exploded view of infrared/visible 4K double camera

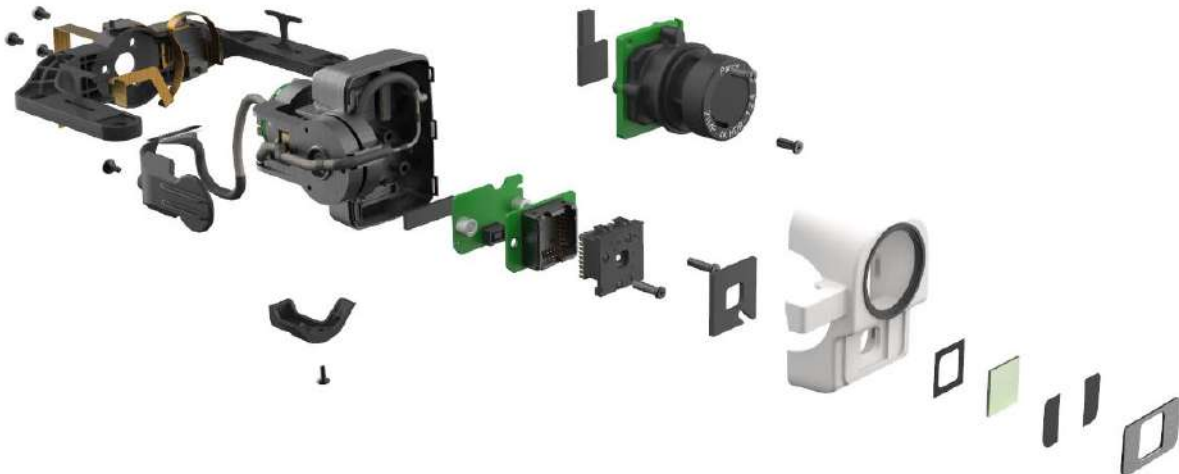

2.3.2.1 4K camera visible spectrum performance

The visible spectrum camera is the same as on ANAFI: it shares its specifications, performance and full range of settings.

ANAFI Thermal integrates an uncooled microbolometer-type FLIR Lepton 3.5 thermal module. It is factory calibrated by FLIR, to set an absolute temperature for each sensor pixel. The module is equipped with a mechanical shutter which enable sensor to recalibrate automatically if conditions require it, thus warranting a the most precise temperature measure.

The Lepton module can be setup according to a double gain mode.

The high gain mode is best adapted to temperatures below 140 °C, it offers a good thermal sensibility on a reduced temperature scale.

The low gain mode is best suited for temperatures above 140 °C.

IR Camera Performance	
Spectral range	Longwave infrared, 8 micrometer to 14 micrometer
Array format	160x120 pixels
Pixel pitch	12 micrometer
Precision	5 °C
Thermal sensitivity	0.050 °C
HFOV	57°
Thermal sensitivity	8.7 Hz
Scene dynamic range	-10 °C to 400 °C
Non-uniformity corrections	Integral Shutter
Video	
Format	MP4 (H264)
Resolution	1440x1080, 9 fps
Stream video resolution	720 p
Photo	
Format	JPEG
Resolution	1440x1080 (4/3)

2.3.3 Color modes

There are 3 color modes (or palettes) for the thermal spectrum, to cover a wide array of exploration needs.

2.3.3.1 Absolute palette

The Absolute thermal mode is the most versatile of ANAFI Thermal's thermography modes. It enables the user to select a custom temperature scale and to focus on it, to achieve extremely precise color readings.

Fig.13 - Absolute palette screenshot



2.3.3.2 Relative palette

The Relative mode is useful to get a quick overview of any scene's temperature range. In this mode, even slight heat differences materialize as strong contrasts.

Fig.14 - Relative palette screenshot



2.3.3.3 Spot palette

The Spot thermal mode of ANAFI Thermal is especially useful to isolate cold or hot spots.

Fig.15 - Spot palette screenshot



2.3.3.4 File format

The following file formats are supported by ANAFI Thermal:

- Photo:
 - format: JPEG
 - resolution 1440x1080 (4/3)
 - modes: single / Time-lapse / GPS-lapse
- Video:
 - format: MP4 (H264)
 - resolution: 1440x1080, 9 fps

2.3.3.5 Compatibility with FLIR Tools®

Thermographic pictures taken by ANAFI Thermal are compatible with Flir Tools thermal analysis and reporting software.

Videos captured by ANAFI Thermal contain: the main, video blending track (visible + thermal); a visible only track; thermal raw data – which users can use to re-blend videos and recalculate each pixel temperature, in post treatment.

2.3.4 Infrared / Visible fusion

To compensate for the lower resolution of the thermal image compared to visible, and to benefit from information from both spectrums, the image displayed is a customizable (0 to 100 % in each spectrum) blending of information from both sensors. Visible image data is injected into the output image through the scene luminescence and its outlines.

The image fusion consists of:

- Visible image acquisition

The visible image is managed by the Ambarella H22 ISP processor, resulting in a 1440x1080 (video mode) stabilized rectilinear image.

Capture is done at 8.7 GHz and is time synced with the thermal image acquisition.

The factory calibrated misalignment of units is compensated to align the visible camera orientation with the thermal camera orientation.

- Thermal data acquisition

Raw thermal images 160x120 14 bits are acquired via USB at 8.7 GHz.

This raw data is converted into 16 bit Kelvin temperature with a 1/64th Kelvin granularity.

- Thermal data projection

Temperature data (160x120) is re-projected to the overall image dimension (1440x1080 for video) and to the visible image orientation (EIS), using a bilinear interpolation.

The thermal image EIS is performed by overall image transformation.

- Thermal image coloring

Temperature data (1440x1080) are colored in the YUV domain according to the different settings selected by the user:

- Color palette
- Min/Max temperature values for the color palette.

2.3.5 About infrared streaming

Although the sensor has a 14 bits capacity (16,384 steps), the practical range is coded on 8 bits.

To make it more meaningful to the user, there is up to 256 steps to represent the scene when the zoom is set to x1.

3 FLIGHT CONTROLLER/FLIGHT MODES

3.1 Key characteristics

ANAFI Thermal's flight controller offers an intuitive and easy flight experience: no training is required to fly. The flight controller allows the automation of numerous flight modes and functions (Flightplan, Follow Me, Cameraman, Hand take-off, Smart RTH).

3.2 Flight controller

3.2.1 Components

ANAFI Thermal's flight controller uses an Ambarella H22 processor, an MPU-6000 InvenSense IMU, an AK8963 AKM magnetometer, an UBX-M8030U-BLOX GPS, an ultrasonar, a barometer and a vertical camera. The Parrot flight software gathers data from all sensors to estimate the altitude, the position and the speed of the drone.

3.2.2 Sensor performance

3.2.2.1 InvenSense MPU-6000 IMU

3-axis gyroscope

- Range: $\pm 2000^\circ/s$
- Resolution: $0,03^\circ/s$
- Bias/accuracy: $\pm 7^\circ/s$ (after compensation)
- Stabilization at temperature (50 °C)

3-axis accelerometer

- Range: $\pm 16\text{ g}$
- Resolution: $0,2\text{ mg}$
- Bias/accuracy: $\pm 15\text{mg}$ (X-Y) $\pm 67\text{mg}$ (Z) (after compensation)
- Thermal calibration and stabilization at temperature: 50 °C to $\pm 0,1\text{ }^\circ\text{C}$
- Measured frequency: 1 KHz

3.2.2.2 AKM AK8963 magnetometer

- Range: $\pm 49000\text{ mG}$
- Resolution: 6 mG
- Bias/accuracy: $\pm 10\text{ mG}$ (after compensation)

3.2.2.3 ST Microelectronics LPS22HB barometer

- Range: $260\text{-}1260\text{ hPa}$
- Resolution: $0,0002\text{ hPa}$
- Bias/Accuracy: $\pm 0,1\text{ hPa}$
- Measuring frequency: 75 Hz
- Measure noise: 20 cm RMS

3.2.2.4 U-BLOX UBX-M8030 GPS

- Sensibility: cold start -148 dBm – tracking & navigation: -167 dBm
- Time-To-First-Fix: 35 seconds
- Position: $1,2\text{ m}$ standard deviation

- Speed: 0,5 m/s standard deviation
- 4 constellations: GPS L1, Galileo E1, Glonass L1 and BeiDou B1C activated
- Frequency centered on GPS L1 implies lower gain on Glonass:
 - GPS L1: +0 dB
 - Galileo E1: +0 dB
 - Glonass L1: -4 dB
 - BeiDou B1C: +0 dB

3.2.2.5 Ultrasonar (height measurement)

- Sonic frequency: 40 KHz
- Measuring frequency: 17 Hz
- Max range on concrete: 5 m
- Max range on grass: 2 m

3.2.2.6 Vertical camera (measuring horizontal speed and height using optical flow)

- Sensor: MX388
- Resolution: 640x480
- Global shutter
- Black & white
- FOV: 53,7°
- V FOV: 41,5°
- f:2,8
- Optical flow at 60 Hz to calculate ground speed
- During hovering and precise landing, points of interest are measured at 15 Hz
- Speed estimation: 160x120 pixels - 60 fps
- Precise hovering: 160x120 pixels - 15 fps

3.2.3 Estimation algorithm

It estimates the states of the drone. An extended Kalman filter collects all sensors data to monitor 18 physical states:

- Speed on all 3 axes (x body, y body, z body)
- Attitude (phi theta psi)
- Accelerometer biases (x, y, z) of component manufacturing, the welds, aging and temperature
- All biases from the 3-axis gyroscope
- Pressure sensor bias
- x, y, z position on a NED plane
- Wind on x & y

The magnetometer bias on x, y, and z is estimated by merging data from the gyroscope and magnetometer. Ground distance is estimated by merging the Kalman filter estimated vertical speed and the optical flow from the vertical camera.

The thrust model's correction factor is calculated from the delta between the acceleration predicted by the drone's dynamic equation on z-axis and the accelerometer sensed value. This factor allows the calculation of the drone's balance control in order to compensate for its own weight.

3.2.4 Control loop

The control loop runs at 200 Hz. It manages all instructions sent to the motors, including all commands linked to altitude, positioning, attitude and control blending.

3.2.4.1 Altitude instructions

- Trajectory and feedforward generation uses an ideal model: it dissociates trajectory dynamics from disturbance rejection while reducing altitude control errors
- PID type altitude control

3.2.4.2 Position control loop

- Trajectory and feedforward generation using an ideal model: it dissociates trajectory dynamics from disturbance rejection while reducing positioning control errors
- PID type position control
- Wind correction

3.2.4.3 Attitude instructions

- Trajectory and feedforward generation using an ideal model: it dissociates trajectory dynamics from disturbance rejection while reducing attitude control errors
- PID type attitude control
- Aerodynamic torque compensation
- Estimation of external torques

3.2.4.4 Commands blending

- Blending of altitude and attitude commands allow to derive motor instructions and their saturation
- Commands are prioritized in the following order:
 - Pitch
 - Roll
 - Altitude feedforward
 - Yaw
 - Altitude

3.3 Flight modes

3.3.1 Precise Hovering

While hovering, the drone's vertical camera captures a reference frame. It is then compared to subsequent shots taken at 15Hz. The algorithm calculates the camera movement that would minimize the reprojection error between the reference photo and more recent one. This movement is then used as an instruction for the autopilot.

ANAFI Thermal is stable within a 1.5 cm radius-sphere at 1 m height.

The algorithm also allows for yaw stabilization and contributes to the overall image stabilization performance.

3.3.2 Precise Return Home (RTH)

At the end of the take-off sequence, the vertical camera takes a picture. When the drone lands, or hovers above the RTH target, the algorithm takes a new picture. The algorithm then measures the reprojection error between the two pictures, which serves as an instruction for the autopilot.

3.3.3 Smart RTH

The drone keeps track of the amount of energy needed to return to its take-off position. It analyzes the distance already flown as well as the wind resistance encountered and compares these values with the remaining energy of the battery. When only a thin safety margin is left, the RTH function is automatically initiated - which can be cancelled by the user.

3.3.4 Automated take-off

The drone stabilizes at 1 m height, hovering. It uses its GPS and vertical camera to hold its position, even despite strong winds.

3.3.5 Hand take-off

The drone's motors start rotating at minimal speed and wait to detect the launch. It then stabilizes at the same height at which it was launched.

3.3.6 Low altitude flight

The drone can fly as low as 50 cm from the ground.

3.3.7 Automated landing

Regardless of the drone's altitude, when the remaining energy of the battery is close to that needed to land safely, the emergency automated landing sequence initiates. The user can still control the drone horizontally to reach a convenient landing spot, but he cannot cancel the landing.

3.4 Flying Modes

3.4.1 Manual

The Parrot Skycontroller 3 allows you to fly in four different control modes.

	Left joystick	Right joystick
Mode 1	Elevation & rotation	Direction
Mode 2	Direction	Elevation & rotation
Mode 3	Acceleration & rotation	Elevation & rotation
Mode 4	Elevation & rotation	Acceleration & rotation

3.4.2 Automatic

3.4.2.1 Follow Me

The user selects himself on the screen (double tap or tap & drag), ANAFI Thermal follows the user from up to 30 m away.

Fig. 4 - Follow Me screenshot

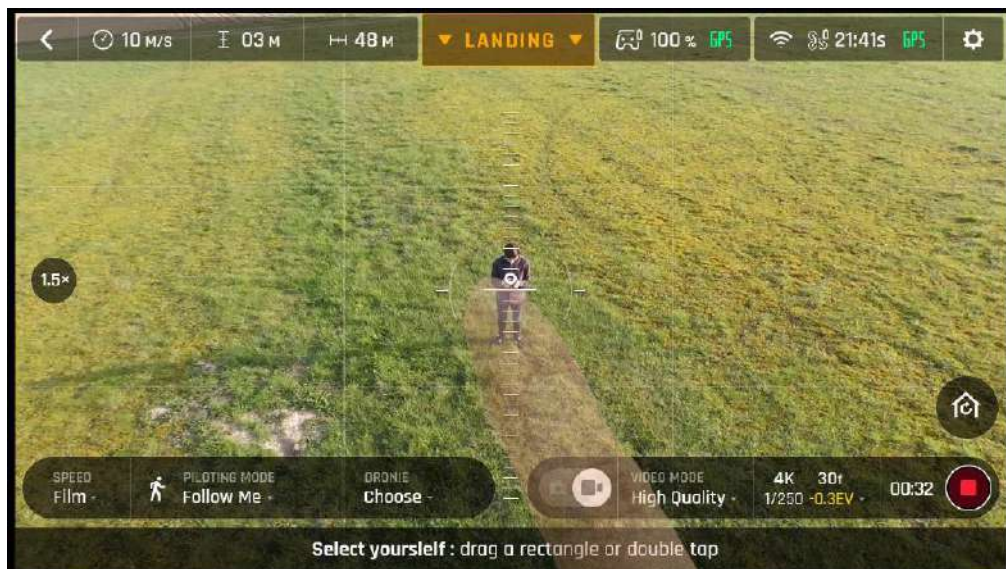

The Follow Me mode combines visual and GPS tracking algorithms.

Visual tracking combines:

- 1) a motion model of the target's position in relation to the drone's position;
- 2) a visual tracking algorithm (optical flow and online learning based on SVM);
- 3) a target segmentation algorithm.

The SVM algorithm initiates tracking with a single shot and keeps updating target recognition. The algorithm can manage changes in the silhouette of the target – for example, the algorithm follows the directional changes of a moving vehicle (side view followed by rear view).

The algorithm is robust: the convolutional neural network identifies objects within the scene regardless of the orientation of the tracked silhouette. Its use is optimized for portable devices.

This convolutional neural network is trained on public VOC and COCO databases and fine-tuned on a Parrot drone images database, ensuring the highest level of reliability.

This neural network can detect cars and pedestrians:

- Target height > 1/3 the image: 100 % detection level
- Target height > 1/8 the image: 66 % detection level
- Target height > 1/15 the image: 50 % detection level

Finally, a Kalman filter performs the GPS/Vision merging.

3.4.2.2 Cameraman

This mode implies selecting a target (person, vehicle, building, animal, etc.) on the screen (double tap / tap & drag). When activated, the camera keeps the target framed (roughly 30 m range, depending on the size of the target).

The visual tracking is based on the same algorithm as the Follow Me mode.

The algorithm (neural network and proprietary AI) adapts to the evolution of the shape and directional changes of the target.

The pilot concentrates on the flight while the camera automatically adapts its framing (pitch and yaw) to keep the target in its frame.

3.4.2.3 Touch & Fly

The Touch & Fly flight mode enables the user to define the destination of the drone with a simple touch on the screen.

The GPS coordinates of the selected location are transmitted to the drone.

Fig. 5 - Touch & Fly screenshot



3.4.2.4 Flight Plan

The Flight Plan function of FreeFlight 6 enables users to prepare their missions offline, directly on their screen of their device by selecting waypoints, altitude and camera axis. Parrot has simplified the ergonomics of mission planning, which is usually a complex task. Each flight plan can be saved and edited without limitation. A flight plan is possible even without radio connection.

Fig. 6 - Flight plan screenshot

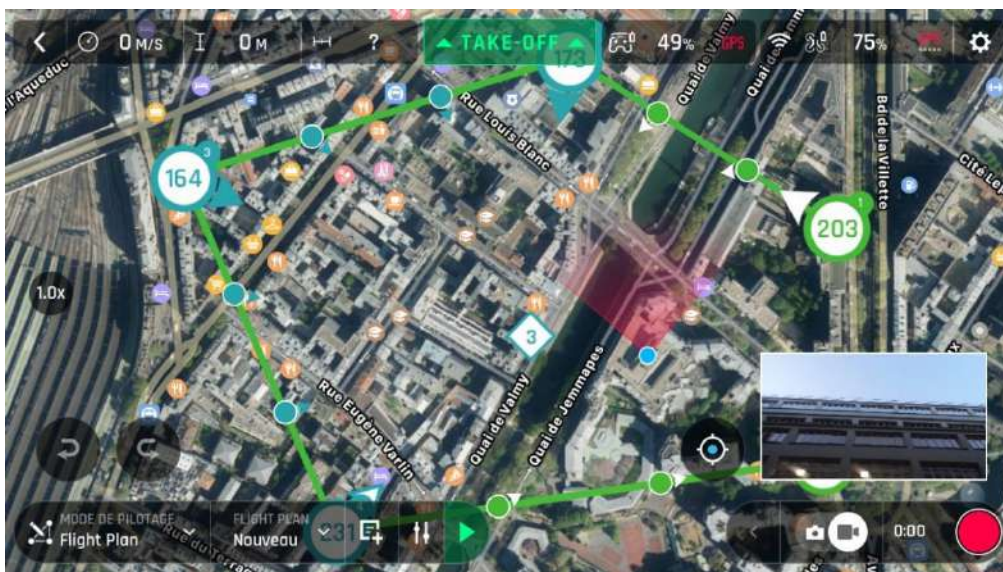

3.4.2.5 Automated flight

The Cineshot function of FreeFlight 6 carries 4 automated shots (360, Reveal, Spiral, Epic). Parrot can also program and automate specific flight sequence-shots upon request.

4 FREEFLIGHT 6

4.1 Key characteristics

- FreeFlight 6 is not only a drone piloting application, but a complete interface from which users select all their flight, photo and video settings. It can be used in conjunction with the Parrot Skycontroller 3 controller or without, in a device only set-up.
- ANAFI Thermal can be configured and ready for flight in 28 seconds.
- ANAFI Thermal is equipped with a 16 GB microSD card which can record a full flight (25 minutes) in 4K.

4.2 HUD

The HUD (Head-Up Display) is the ergonomic interface of FreeFlight 6, presenting flight controls, settings and telemetry on a single screen:

- Altitude
- Distance
- GPS
- Drone battery level
- Controller battery level
- Radar

Fig. 7 - Freeflight UI - video stream & controls

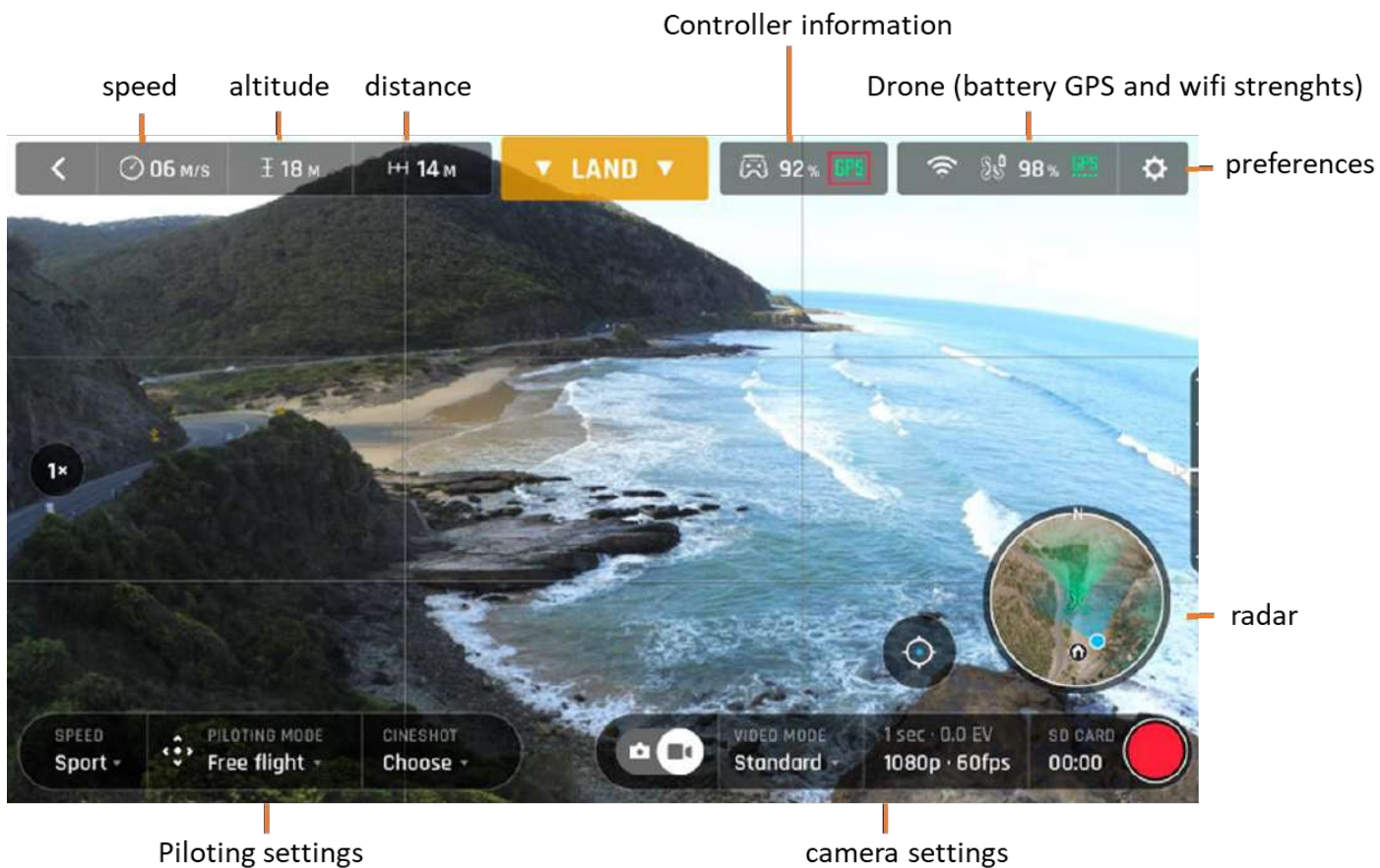

4.3 Flight Plan UI

Each Flight Plan is programmed using waypoints. The altitude and camera axis of each waypoint is customizable. The drone speed can be modified between each waypoint. The camera axis can be oriented toward a Point of Interest (POI), forcing the drone to focus on the POI during the flight.

Note: there is no software limitation on the number of Flight Plans that can be recorded.

Since the Freeflight 6.5 release on Android devices, users can import a flight plan from a JSON file to the application. The flight plans created in FreeFlight 6 are also readable and editable from computer.

Fig. 8 - Flightplan screenshot



4.4 Map backgrounds

Available cartographies: iOS or Android
Other cartographies are available upon request.

Fig. 9 - iOS Cartography

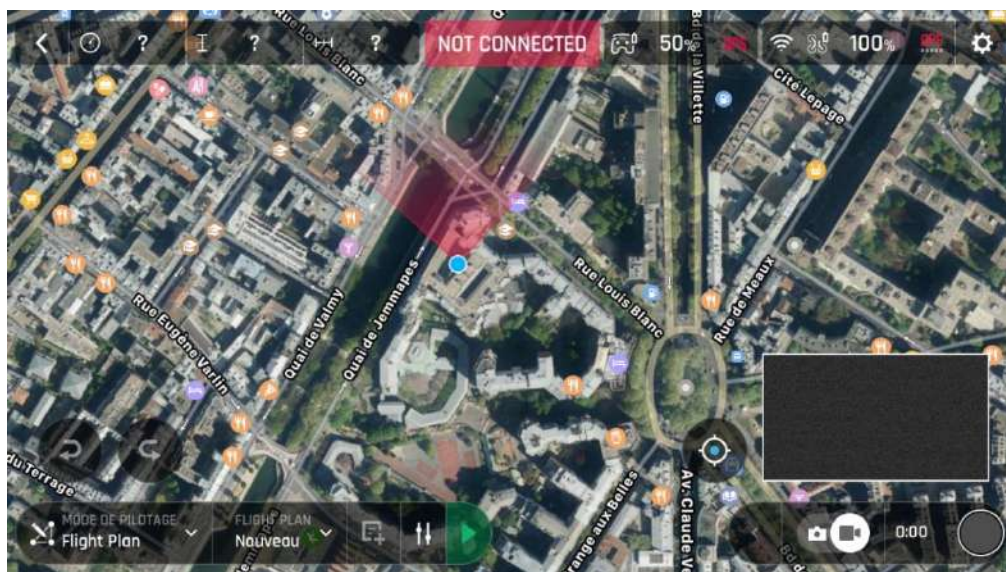

4.5 Visualizing media

Media transfer is available directly from ANAFI Thermal without extracting the microSD card, using an USB cable. Media transfer is also possible directly from the Freeflight 6 gallery to a device. The double gallery of Freeflight 6 separates media stored on ANAFI Thermal's microSD card and ANAFI Thermal media downloaded on the device.

4.6 Automated updates

FreeFlight 6 updates may also carry one or more of the following updates:

- Drone firmware
- Battery firmware
- GPS
- WIFI chipset firmware
- Parrot Skycontroller 3 controller firmware

4.7 GSDK

ANAFI Thermal's Software Development Kit (SDK) is available to the public. It contains:

4.7.1.1 GroundSDK: Available for iOS (Swift et Objective C) and Android (JAVA)

The GroundSDK framework allows the user to develop his own mobile applications, based on the controls or the video stream of ANAFI Thermal, for example. GroundSDK, including its entire libraries, is available as an open source package, ready to compile – as well as in CocoaPods (iOS) and ARR (Android).

The code is published under BSD-3 license and comes with an installation guide, API documentation, as well as a demo application.

4.7.1.2 PDrAW: Available on Unix systems (Linux and MacOS)

PDrAW and its suite are a set of software libraries and tools allowing the user to exploit live video stream (RTP) as well as recorded ones (MP4).

PDrAW is used by GroundSDK on Android and iOS and it can be used independently on Linux and MacOS environments.

PDrAW and its suite are available in open source code. The code is published under license BSD-3 and comes with an installation guide and API documentation.

4.7.1.3 SPHINX Simulator

This software-in-the-loop simulator allows us to simulate ANAFI Thermal in 3D in real time. Sphinx is based on the open source robotic simulation framework Gazebo.

ANAFI Thermal's firmware, as simulated on an emulated hardware (camera, sensors and actuators), is identical to ANAFI Thermal's actual software. The simulator allows automated testing (headless) and alteration of a hardware peripheral, in real time.

4.7.1.4 MAVLink Compatibility

The ANAFI Thermal platform is compatible with the open source protocol MAVLink v1, that allows real time data exchange between the drone and a control station. ANAFI Thermal can be piloted manually or through an automatic flight plan from any MAVLink V1 station, such as QGroundControl.

Fig. 10 - MAVLink protocol

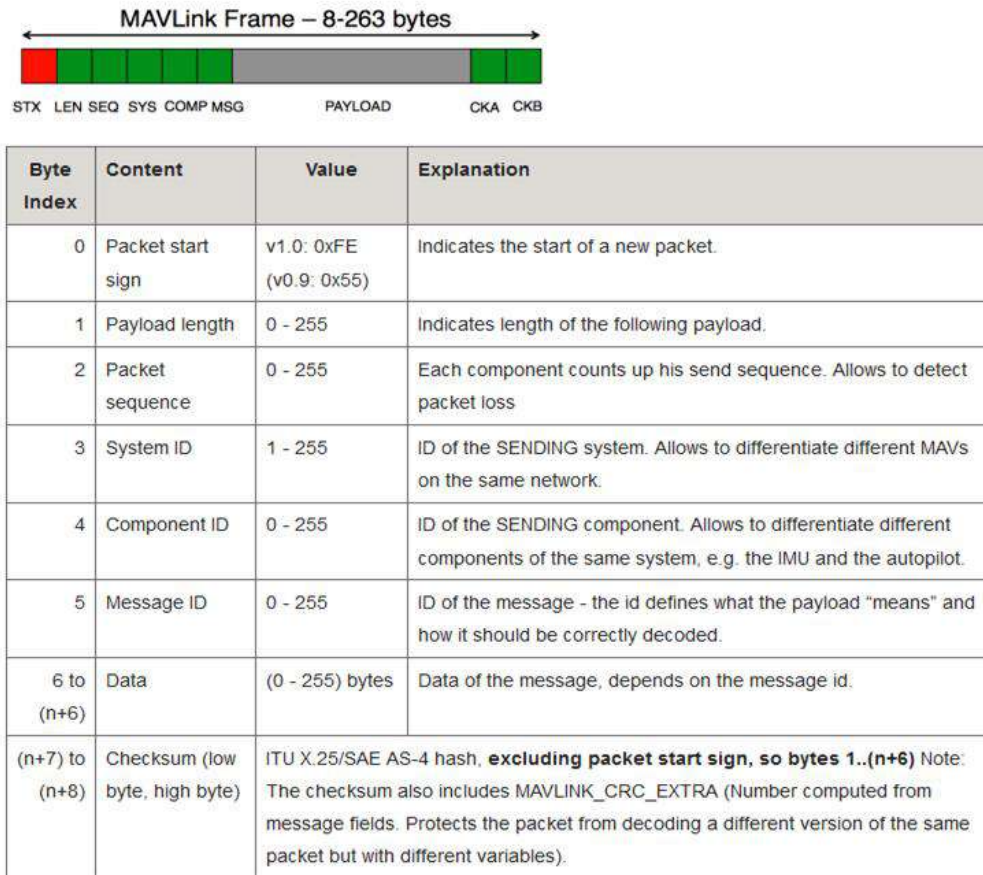
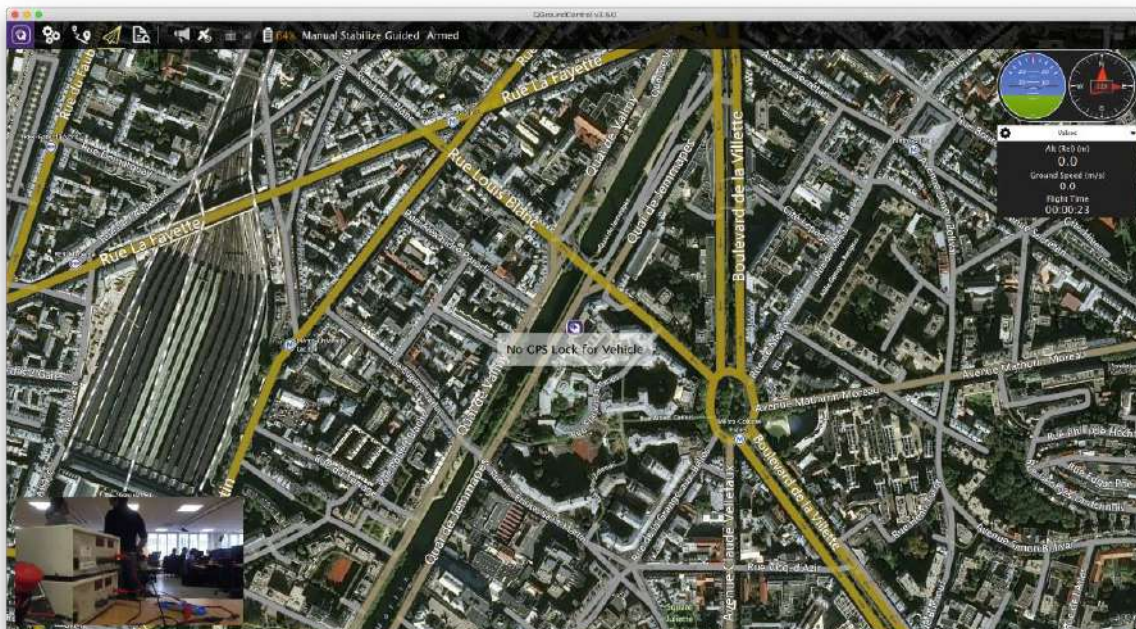

Fig. 11 - QGroundControl ANAFI Thermal piloting interface



5 VIDEO STREAMING

5.1 Key characteristics

- H264 encoding with RTSP and RTP transmission protocols
- The video stream is compatible with RTP-compatible players, like VLC or mplayer
- Live stream: 720 p (HD) 30 fps, 5 Mb/s
- Compatible with the following H264 and MPEG standards
- Reduced latency (280 ms from end to end)

5.2 Stream performance

<i>ANAFI Thermal Video stream performance</i>	
Resolution	720 p
Frame rate selector	24/25/30
Stream rate	5 Mb/s
Bit rate	Up to 5 Mb/s
Video encoding	H264 main profile
Protocol	RTSP and RTP (VLC compatible)
Latency	280 ms from end to end

5.2.1.1 Video stream optimization algorithms used

5.2.1.2 Advanced encoding for Error resilience

The H264 stream is designed to minimize the impact of packet losses and to dilute errors. The algorithm combines slice-encoding and a periodic intra-refresh. It encodes images as 45 slices of 16 pixels height, then refreshes them by batch of 5, every 3 images (the refresh is complete every 29 images).

5.2.1.3 Error concealment

Reduces glitches and packet loss of the video stream.

5.2.1.4 Congestion control

The algorithm consistently scans radio and Wi-Fi bands to avoid losses and packet congestion and to reduce latency.

5.2.1.5 Metadata

The video stream contains telemetric flight data (altitude, GPS, speed, etc.). This data is available for SDK integration.

6 BATTERY

ANAFI Thermal's battery is the most evolved on the light drones' market.

6.1 Key Characteristics

- High density
- Intelligent power management
- Wintering
- Smart charging
- Quality control

6.2 Performance

Battery Performance	
Weight	125 g
Battery Energy density	164 Wh/kg
Charging Time	90 min
Energy	HD battery (HV)
Cells	LiPo 2S
Capacity	2700 mAh 8 V
Charger	USB-C Power Delivery Charger
Cycle Life	94 % remaining capacity after 360 cycles
Storage Temperature	-20 °C/40 °C
Minimal take-off temperature	-14 °C (21 min)
Typical take-off temperature	40 °C (25 min)
Maximal take-off temperature	+60 °C (13 min)

6.3 Features

6.3.1 Smart power management

ANAFI Thermal's battery integrates a power gauge which accurately monitors, every 250 ms, the battery voltage, the charge and discharge currents, and the battery temperature.

The battery determines the available charge, battery run time, and battery state-of-charge (SOC) using the gauge parameters, the age of the battery, as well as its state-of-health. The state-of-health of a battery is a figure of merit of its current condition relative to its nominal capacity -2700 mAh for ANAFI Thermal.

The accurate control of battery parameters allows the integration of the Smart RTH feature: ANAFI Thermal calculates in real time the amount of energy necessary (critical threshold) to return to its take-off position. ANAFI Thermal automatically returns to its take-off point when the battery reaches the critical threshold.

6.3.2 Wintering

After 10 days of inactivity, the battery automatically enters wintering mode, which keeps the battery at an optimal state-of-charge (60 % of the nominal charge) in order to extend its lifetime.

This mode ensures the best possible preservation when batteries are stored. It eliminates leakage current by isolating the cells from the motherboard, thus avoiding a weak voltage level to be drawn (3 V) that would damage the battery.

6.3.3 Storage

The battery can be stored for 10 months as is, by maintaining the voltage across the cell terminals at a higher voltage level (3 V) than the deterioration voltage.

Storage conditions: between -20 °C and +35 °C with humidity lower than 75 %.

6.3.4 Smart charging

ANAFI Thermal's battery are easily and quickly charged by any USB-C adapter, through its unique 18 W integrated charger - a first on the market. Furthermore, the battery is USB Power Delivery compatible, for a fast USB charge. With a USB 3.0 Power Delivery adapter delivering 9 V to 12 V, the battery is fully charged in 90 minutes.

Unlike most other drones, ANAFI Thermal's battery is equipped with an onboard charger, making it a lot less cumbersome. ANAFI Thermal's Parrot Skycontroller 3 and batteries are charged through the same USB-C charger that would charge a PC or a mobile phone.

Charging conditions: between -10 °C and +45 °C with humidity lower than 75 %.

6.3.5 USB-C Interface

The battery's USB-C port allows for external charging of a device such as a 4G USB key; a CO2 sensor; any other compatible device connected through USB.

6.3.6 Powerbank

The battery can be used as a power bank for many types of devices (smartphone, tablet, etc.).

6.3.7 Charge indicator

When charging, the 4 LED on the battery indicate its charge level.

When the battery not connected to the drone, the charge level can be displayed by pressing the ON/OFF button.

When the drone is powered on using the battery, the number of LED indicates the remaining flight time.

6.4 Quality

- Parrot is ISO9001 certified
- The batteries are CE and FCC certified
- The batteries are UM383 certified (transport certification)
- Quality control at the battery supplier facility: Parrot has imposed a reinforced quality control on battery production (supplier audit, QC controls), including test benches which monitor the assembly at each production stage.
- Manufacturing control: Parrot performs quality checks at the drone manufacturer facility. Every battery is checked on a test bench during production, on a wide series of parameters: voltage, current, impedance, smart battery and wintering functions.
- Parrot performs random sampling to check cell quality (folding, assembly and connectors), using X-ray and tomography.

Fig. 1 - X-ray of an ANAFI Thermal battery

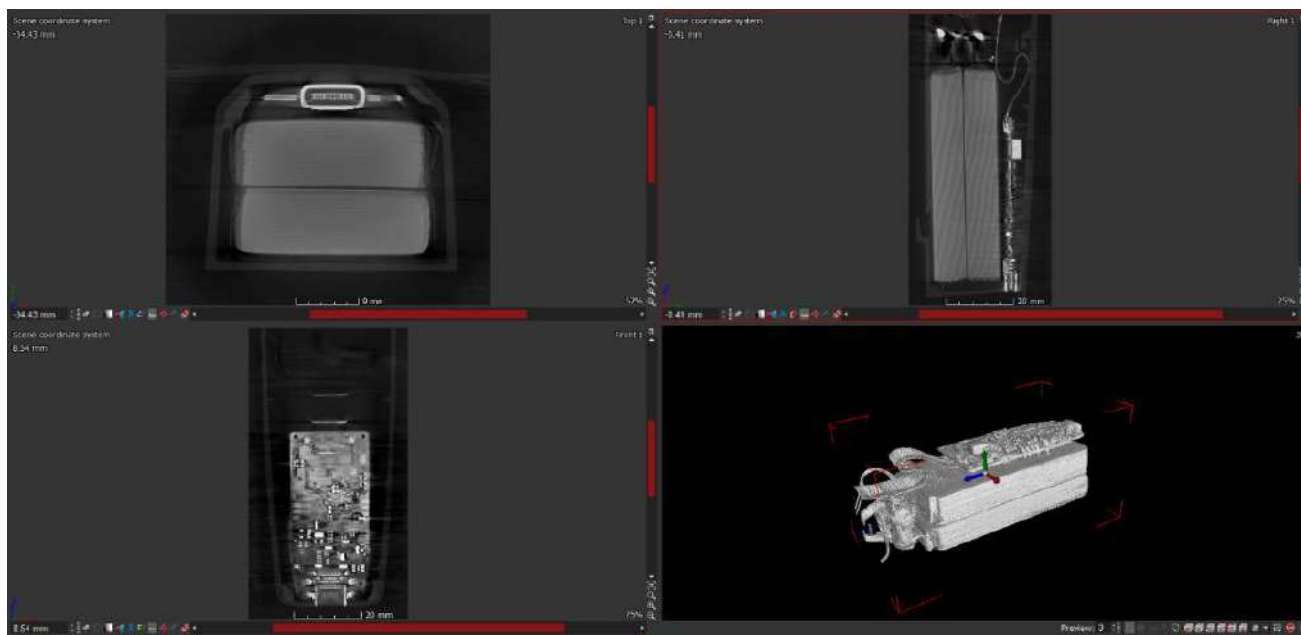

- Storage checks: the state of batteries (state-of-charge) stored by Parrot is controlled every 4 months.
- Firmware update: the battery's firmware is updated over the air (OTA) to provide the latest improvements and the bug corrections.
- Wintering mode prevents the battery from degrading while reducing storage risks.
- Freeflight 6 notifies the user in case of battery defect.